



A Single Stage High Power Factor Supply Based on Buck Flyback Converter

^{#1}Sharath Chandra Nuthi - M.Tech Student,

^{#2}P.Ashok - Assistant Professor,

^{#3}Kamani Sadanandam - Associate Professor & HOD,

Department of Electrical and Electronic Engineering,

MOTHER THERESSA COLLEGE OF ENGINEERING & TECHNOLOGY, Peddapalli, Karimnagar, TS, India.

Abstract: In recent years, power converters are used to get high power factor. This paper presents an integrated converter topology for driving HB LEDs which provides high power factor. The integrated buck flyback converter is a single stage, low cost, high power factor AC-DC converter with fast output regulation. The converter is used to provide power factor correction in streetlight application. To obtain high power factor, the buck stage and flyback stage are operated in discontinuous mode. Dimming operation of HB LED is also described. A closed loop is used for enabling the PWM dimming. The simulation studies using MATLAB/Simulink is also presented. Hardware setup of open loop is described.

Keywords: HB LEDs, IBFC topology, ac/dc converter, DCM, power factor correction, single-stage, driver, PIC.

I. INTRODUCTION

With the development of high brightness light emitting diode (HB LED) technology, the output light efficiency of power LEDs has increased over 100 lumens/W [1]. The HB LED can be used as a solid state light source in general lighting applications. In addition to high efficiency, it has no mercury content and has a longer life. In the future, the power LED is likely to replace the existing lighting sources like the incandescent lamp and fluorescent lamp.

In this paper, the main purpose is to present a topology for driving LED streetlight from an AC source. The important advantages of LEDs are reduced maintenance costs and high colour rendering index. Hence, colour reproduction is much better with LEDs than with LPSV lamps, since the latter emit only in the yellow wavelength. In addition, HB-LEDs do not exhibit either warm-up or restart periods, thus avoiding the need for extra control circuitry.

Since streetlights are powered from an ac source, they must comply with the International Electrotechnical Commission (IEC) 61000-3-2:2005 mandatory regulations in terms of harmonic content and power-factor correction (PFC) [2]. Additional requirements are that the electronic ballast must achieve high energy efficiency and be dimmable by pulse width modulation (PWM) technique.

In general lighting applications, high power factor can be achieved using either a passive circuit or an active circuit [3], [4]. The passive circuit consist of inductors and capacitors together with uncontrolled rectifier. This is a good solution to achieve high power factor and does not generate electromagnetic interferences (EMI). However, it is difficult to achieve a higher power factor and lower THD with a passive PFC which uses only capacitors and inductors. Due to the presence of inductors and capacitors the size of the passive power correction circuit is large. So it is only suitable for low power applications.

In active power factor correction circuit, switch mode power supplies are used to achieve high power factor, low THD, and good output voltage regulation. Active power factor correction circuit is divided in to two categories, the two stage and single stage approaches. Single stage is the simplest active PFC circuit.

The most common single stage topologies used are the boost converter, the buck-boost, or buck-boost derived topologies. Block diagram representation of single stage power factor correction circuit is shown in Fig. 1. The single stage converter with PFC increases the stress on the switch in the converter due to input current and PFC voltage, and there is a power balance problem. Moreover, dimming of LEDs must be carried out at frequencies above 125Hz [5]. Therefore when dimming operation is required, these single stage solutions are not feasible.

Due to the above reasons, a two-stage converter is needed in order to perform PFC properly and to obtain a fast enough output dynamics. Block diagram of two stage power factor correction circuit is shown in Fig. 2. This system implementation consists of a PFC preregulator followed by a dc-dc converter in cascade. This scheme is usually implemented by means of a boost converter for the first stage and forward buck-boost-derived topologies or flyback converters for the output converter. In addition, even buck converters may be used for the former. These topologies are a very good solution, reaching unity power factor and providing fast output dynamics. The disadvantage of two stage converters are high cost and size and the efficiency of the conversion is penalized because the output power is processed twice.

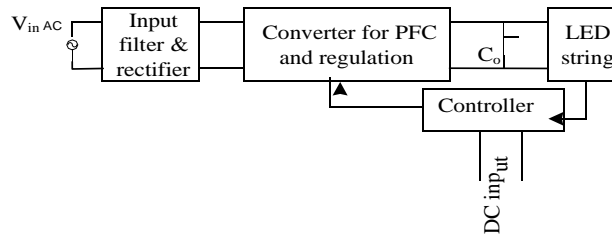

Fig. 1. Block diagram of single-stage power factor correction circuit

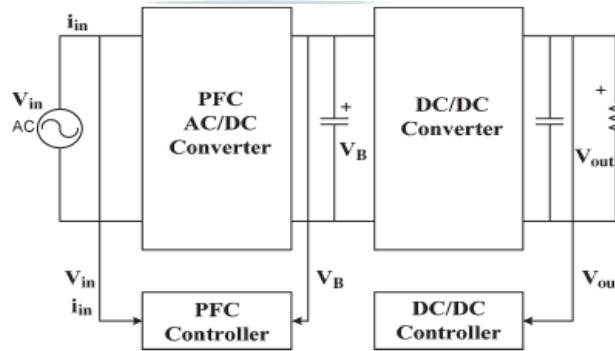

Fig. 2. Block diagram of two stage power factor correction circuit

A good solution is to implement the so-called integrated single-stage (ISS) converters, which leads to the integration of the PFC stage together with the dc–dc converter [5]. This is achieved by eliminating one transistor and sharing the remaining transistor between the two stages. Block diagram of integrated single stage converter is shown in Fig. 3. These topologies are not only a good solution when HPF is needed but also can provide a fast output dynamics equivalent to that of two-stage PFC converters. In addition, the size of the whole converter is reduced, and therefore, the costs are reduced too. Moreover, the efficiency is usually very high in case of operation under narrow input-voltage-range conditions because part of the power is processed only once, or just a small part is processed twice within a single switching period.

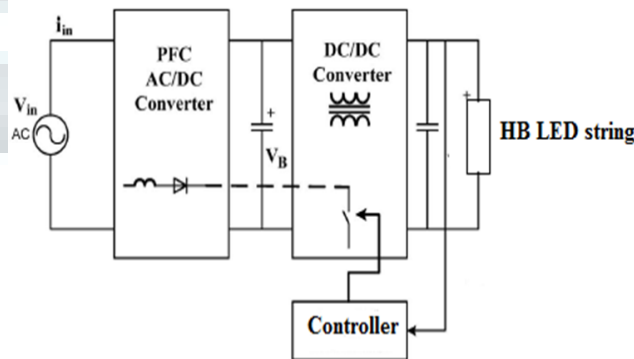

Fig. 3. Integrated single stage converter.

The integrated converter presented in this paper is composed of a buck converter working in DCM integrated with a DCM flyback dc–dc converter. The former is the PFC stage, whereas the latter supplies the power to the LED lamp. Block diagram of IBFC is shown in fig. 4. The converter must be operated in DCM so that HPF can be achieved at the input, while the converter behaves as a current source at the output. The advantages of this topology over boost-based power factor pre-regulators lie in several main aspects. First, the bus voltage is much lower than that of boost or buck–boost based converters. Moreover, this dc bus voltage is not affected by duty cycle or input voltage variations. The bus voltage is depends only on the ratio between the buck and flyback inductances. Second, a lower dc bus voltage requires a lower voltage rating for the bulk capacitor, featuring a lower series equivalent resistance (ESR) device and longer life. Additionally, the buck converter features a natural protection against no-load or short-circuit operation. Another advantage of the IBFC against boost and buck–boost based topologies is that in the proposed ballast, the switch only handles the highest of the buck or flyback current and not the addition of both currents, as what happens in other ISS converters.

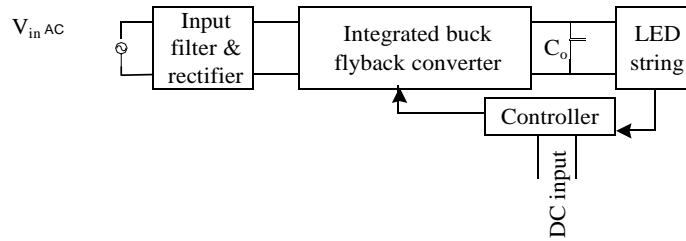

Fig. 4. Integrated single stage IBFC.

II. PRINCIPLE OF OPERATION

A. Circuit Description

The integrated buck flyback converter is shown in Fig. 5. It consists of a buck converter and a flyback converter connected in series. The circuit contains a buck inductor (L_B), a bulk capacitor (C_B), a switch (M_1), flyback inductance (L_F), output capacitor (C_O), and diodes (D_1, D_2, D_3 and D_4).

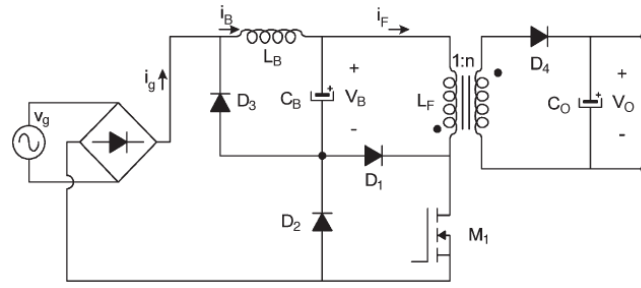

Fig. 5. Integrated buck flyback converter.

B. Circuit Operation

The operation of the IBFC is equivalent to two converters in cascade. The simplest way of operating the IBFC is maintaining the DCM in both buck and flyback inductors. In this way, it will be demonstrated that the bulk capacitor voltage (V_B) is independent of load, duty cycle and switching frequency, and it only depends on the ac input voltage and the ratio of the two buck and flyback inductances (L_B and L_F respectively). This is an important feature of integrated converters operating in DCM, which allows them to provide fast output voltage regulation.

The operation of IBFC during a line half period has two modes.

Mode 1 (0 to t_1): In the time intervals where the instantaneous line voltage is lower than the bulk capacitor voltage ($v_g < V_B$), the rectifier bridge diodes are reverse biased and remain open. Thus, the buck inductance is not energized and diodes D_1 and D_3 are also open during these time intervals. The equivalent circuit is shown in Fig. 6. In this mode, only the flyback converter is operating through switch M_1 and diodes D_2 and D_4 . The operation is exactly equivalent to a flyback converter, where the energy is taken from the bulk capacitor and delivered to the load.

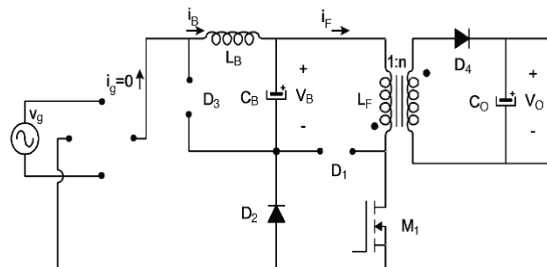

Fig. 6. Equivalent circuit of mode 1: $v_g < V_B$

Mode 2 (t_1 to $(T/2 - t_1)$): In this mode, $v_g > V_B$. In this interval, both buck and flyback inductors are energized when the control switch M_1 is activated. Diodes D_3 and D_4 will remain open and the currents through the buck and flyback inductors are handled by the integrated switch formed by M_1, D_1 , and D_4 . Fig. 7 shows the equivalent circuit of IBFC when M_1 is ON and $v_g > V_B$.

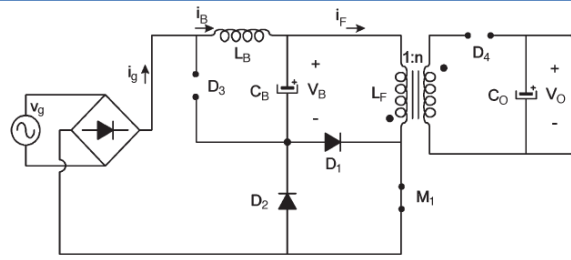

Fig. 7. Equivalent circuit of mode 2: $v_g > V_B$ and M_1 is ON

To understand how the currents are distributed among the three switches when M_1 is ON, an equivalent circuit is shown in Fig. 8. In this circuit, the switch M_1 will handle the higher of the two currents i_B and i_F (buck and flyback currents, respectively). The diode in parallel with the higher current will be open, whereas the diode in parallel with the lower current will be closed. Since the operation is in DCM, the two buck and flyback currents are ramp waveforms starting at the same instant. Therefore, the conclusion is that the current through switch M_1 will be either i_B or i_F , whichever is higher, but not the addition of the two currents. This is an advantage of this converter compared to other integrated topologies, where the currents of the two stages circulate simultaneously through the control switch.

In summary, the current distribution is as follows. When $i_B > i_F$, current i_B will circulate through M_1 , D_1 will handle the current $i_B - i_F$, with D_2 being off. When $i_B < i_F$, current i_F will circulate through M_1 , D_2 will handle the current $i_F - i_B$, with D_1 being off.

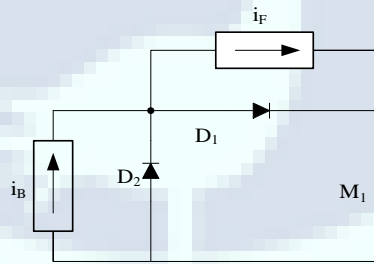

Fig. 8. Equivalent circuit during the conduction of M_1

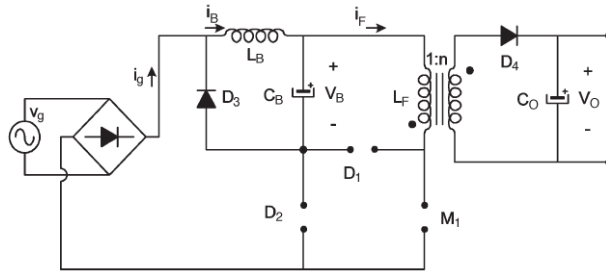

Fig. 9. Equivalent circuit of mode 2: $v_g > V_B$ and M_1 is OFF

Fig. 9 shows the equivalent circuit of IBFC when M_1 is OFF. During this interval, both buck and flyback inductors are being de-energized and the energy is supplied to the bulk capacitor and load, respectively. In this stage, only diodes D_3 and D_4 will be conducting as long as energy remains in the magnetic field of the buck and flyback inductors, respectively. The highest voltage across the switch M_1 (V_{M1}) appears during this interval, can easily be calculated by using the equation (1)

$$V_{M1} = V_g + V_B + V_O/n. \tag{1}$$

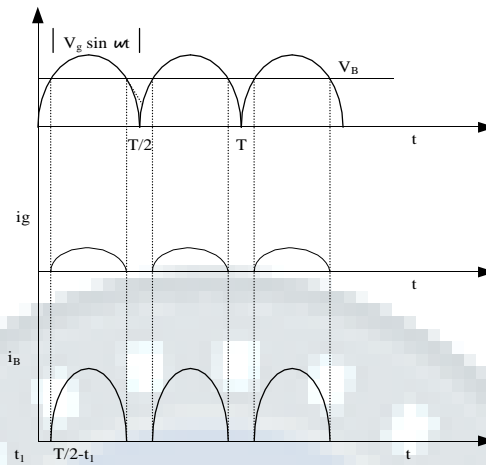

Fig. 10. Input voltage and current waveform of IBFC

III. DESIGN EXAMPLE AND SIMULATION STUDIES

A. HB LEDs and Load Design

HB-LEDs are usually low-power devices, ranging from 1W to 5W at currents from 350 up to 2000 mA. At the present time, their luminous efficiency is around 100 lm/W at 350 mA in the latest devices. The fact that they are low-power devices means that a large number of emitters will be necessary for wide-area-lighting applications such as streetlights.

The nominal power requirement for most LED streetlights ranges from 60 to 150 W. The load finally chosen is made of ten Dragon Tapes running at 350 mA [6-9]. This gives a total of 60 LEDs emitting 1500 lm at 72 W. In order to properly design the power converter, the LED load has to be modeled.

B. Converter Design

The converter was designed to provide a total output power of 72 W, with a rated lamp current of 350 mA. In order to minimize the passive components, a 100-kHz switching frequency was selected.

C. Regulation and Dimming

Taking into account that HB-LEDs are current-controlled devices, a current control is preferable rather than a voltage control. Otherwise, slight changes in the string forward voltage would lead to great changes in the forward current. The flyback converter operating in DCM behaves as a current source, and therefore, an average current control can easily be performed.

PWM dimming can be carried out in three basic ways. The first, called “Series Dimming,” employs a series switch to interrupt the lamp current as commanded by the dimming signal. The main drawback of this solution is the high electrical stresses generated in the series switch. The second one, called “Shunt Dimming,” makes use of a switch in parallel to the load to divert the lamp current as commanded by the dimming signal. The main drawback of this solution is the dissipation of the energy stored in the output capacitor, which is sent to the parallel transistor, reducing the converter efficiency. The last, called “Enable Dimming,” is based on turning on and off the whole converter by means of an Enable/Disable input.

D. Simulation Results

Simulation studies of IBFC which is used for streetlight application is carried out in MATLAB/Simulink. Open loop and closed loop simulation is done. The simulation block diagram of open loop system is shown in Fig. 11 and Fig. 18 shows the closed loop system simulation diagram. Input voltage and current waveforms are shown in Fig. 12 and Fig. 13 respectively. Fig. 14 represents the bulk capacitor voltage and Fig. 15 shows output current. From Fig. 16 it is clear that the input voltage and currents are in phase. Thus we get a high power factor. The THD spectrum of input current is shown in Fig. 17. From this it is clear that the THD is within the limit.

The closed loop simulation is also carried out. A closed loop is designed for enabling dimming operation of LEDs. Fig. 19 represents the input voltage and current. Output voltage is shown in Fig. 20.

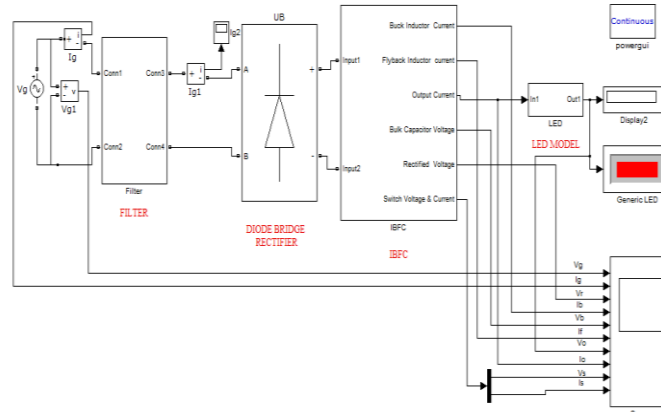

Fig. 11. Simulink model of open loop IBFC used for streetlight application

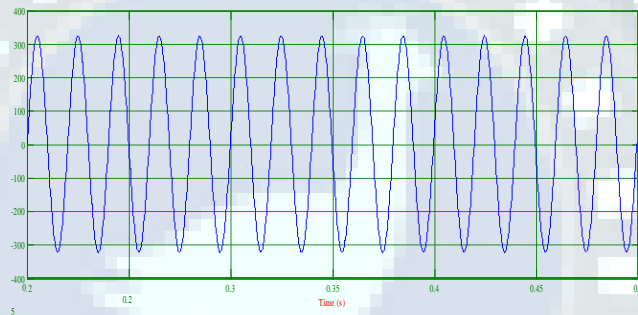

Fig. 12. Input voltage v_g

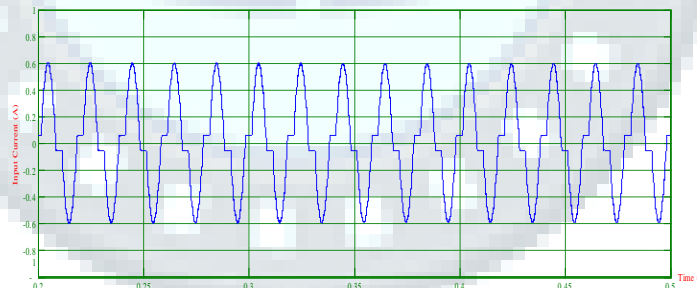

Fig. 13. Input current i_g

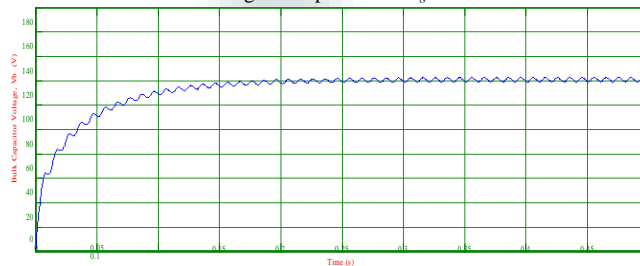

Fig. 14. Bulk capacitor voltage V_B

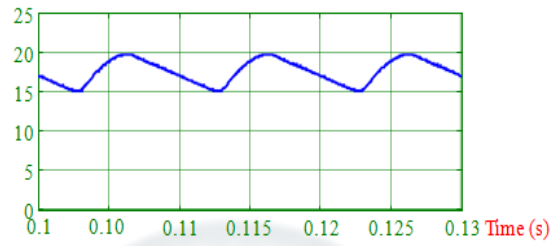

Fig. 15. Output voltage V_o

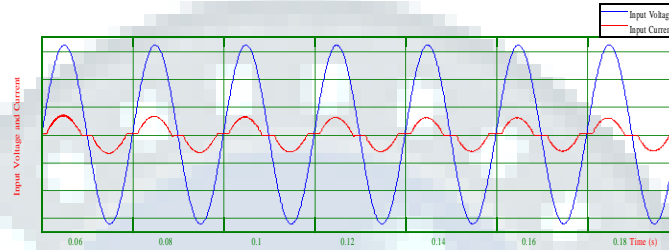

Fig. 16. Input voltage and current waveform

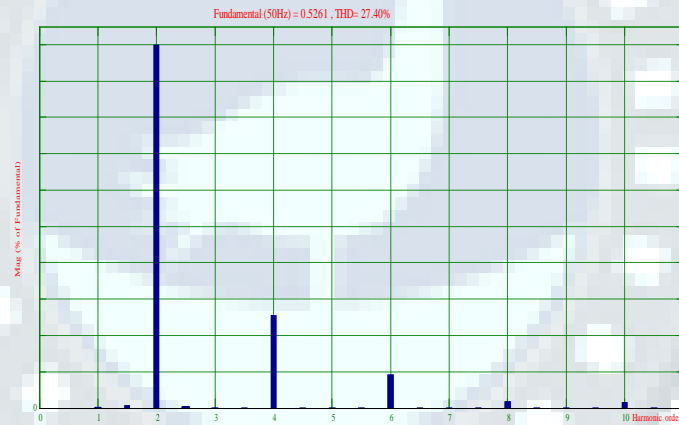

Fig. 17. THD spectrum of input current

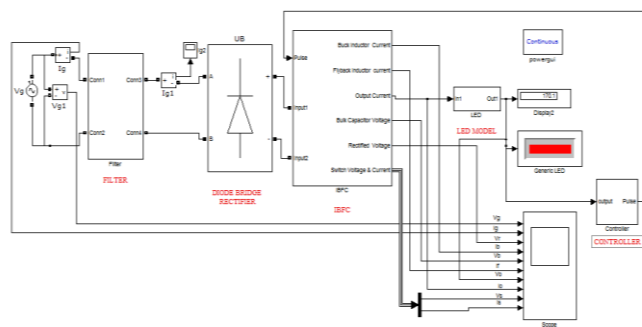

Fig. 18. Simulink model of closed loop IBFC used for streetlight application

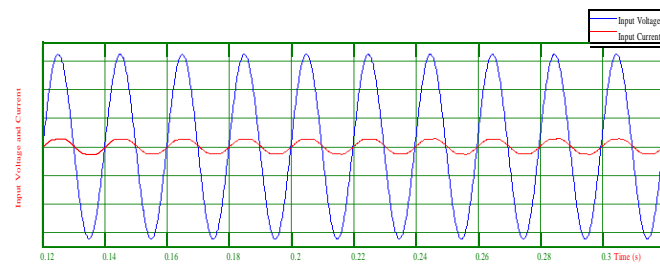

Fig. 19. Input voltage and current of IBFC with closed loop

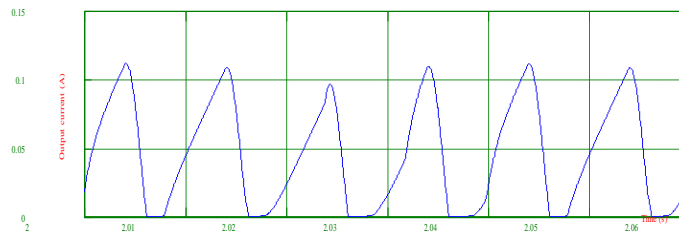

Fig. 20. Output current of IBFC with closed loop

The circuit setup of open loop IBFC is shown in Fig. 21. It consists of controller unit, isolation and driver unit and power circuit module.

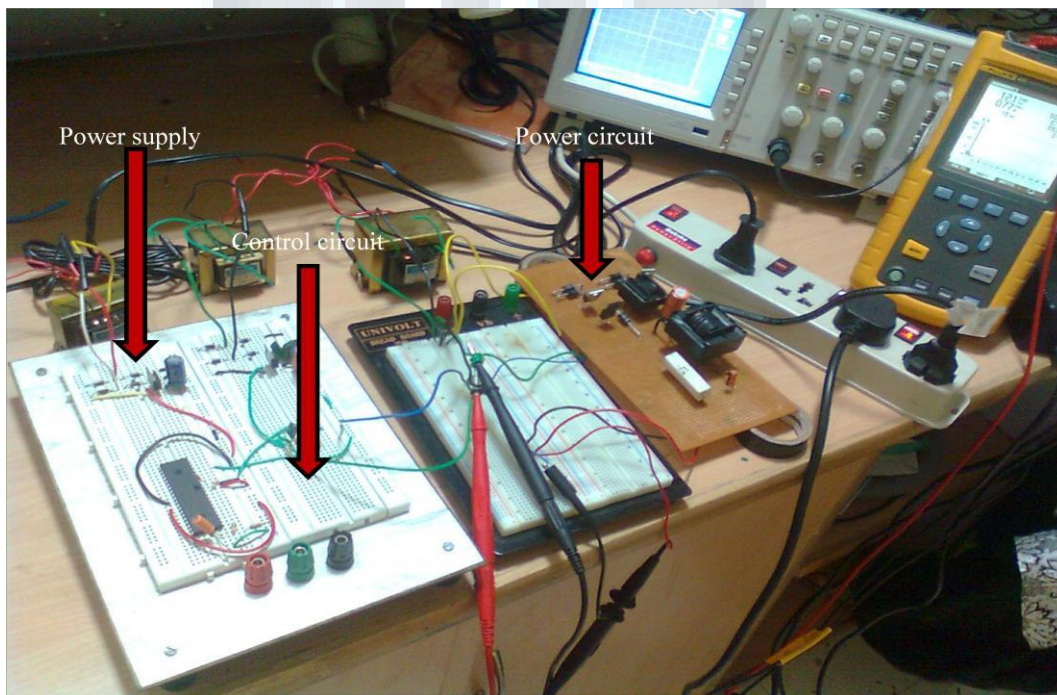

Fig. 21. Circuit setup of open loop IBFC

The power circuit is fabricated in general PCB. Control circuit and power supply modules are setup in the bread board. Input voltage is 12 V, 50 Hz AC and the output is 17 V DC. The switching pulse of 100 kHz is generated using PIC microcontroller.

IV. CONCLUSION

The integrated buck flyback converter used to drive a string of LED is presented in this paper. The IBFC provides high power factor and fast output voltage regulation. It is proposed as a low cost solution for performing power factor correction in LED street lighting applications. A closed loop system for enabling dimming of LED is also discussed.

REFERENCES

- [1] B. Weir and F. Cathell, "LED streetlight demands smart power supply," *Power Electron. Technol.*, vol. 34, no. 2, pp. 34–39, Feb. 2008.
- [2] J. M. Alonso, M. A. Dalla Costa, and C. Ordiz, "Integrated buck–flyback converter as a high-power-factor off-line power supply," *IEEE Trans. Ind. Electron.*, vol. 55, no. 3, pp. 1090–1100, Mar. 2008.
- [3] K. Zhou, J. G. Zhang, S. Yuvarajan, and D. F. Weng, "Quasi-active power factor correction circuit for HB LED driver," *IEEE Trans. Power Electron.*, vol. 23, no. 3, pp. 1410–1415, May 2008.
- [4] O. García, J. A. Cobos, R. Prieto, P. Alou, and J. Uceda, "Single phase power factor correction: A Survey", *IEEE Trans. Power Electron.*, vol. 18, no. 3, pp 749-755, may 2003.
- [5] D. Gacio, J. M. Alonso, A. J. Calleja, J. García, and M. R. Secades, "A universal input single stage high power factor power supply for HB LEDs based on integrated buck flyback converter", *IEEE Trans. Ind. Electron.*, vol. 58, no.2, pp 589-599, Feb. 2011.
- [6] Luxeon K2 With TFFC, datasheet DS60, Jun. 2008.
- [7] "Diamond Dragon," Datasheet LW W5AP (2008-05-15). [8] "Dragon Tape," Datasheet OS-DT6 (2005-03-01).
- [9] "Golden Dragon," Datasheet LW W5SG.